

$$z = \frac{Y^2}{R \left(1 + \sqrt{1 - (1+k) \frac{Y^2}{R^2}} \right)} + A_4 Y^4 + A_6 Y^6 + \dots + A_n Y^n$$

	SURFACE 1	SURFACE 2
SURFACE TYPE	ASPHERIC	PLANO
CLEAR APERTURE (CA)	ø5.10mm	ø4.55mm MIN.
RADIUS OF CURVATURE	8.08262mm	INF.
<i>k</i>	-1.34235	0.0
<i>A</i> ₄	1.81052E-004	0.0
<i>A</i> ₆	-1.60892E-008	0.0
<i>A</i> ₈	6.82628E-010	0.0
<i>A</i> ₁₀	0.0	0.0
<i>A</i> ₁₂	0.0	0.0
<i>A</i> ₁₄	0.0	0.0

VARIABLES	
<i>z</i>	SURFACE PROFILE
<i>Y</i>	DISTANCE FROM OPTICAL AXIS
<i>R</i>	RADIUS OF CURVATURE
<i>k</i>	CONIC CONSTANT
<i>A</i> ₄	4th ORDER ASPHERIC COEFFICIENT
<i>A</i> ₆	6th ORDER ASPHERIC COEFFICIENT
<i>A</i> _{<i>n</i>}	<i>n</i> th ORDER ASPHERIC COEFFICIENT

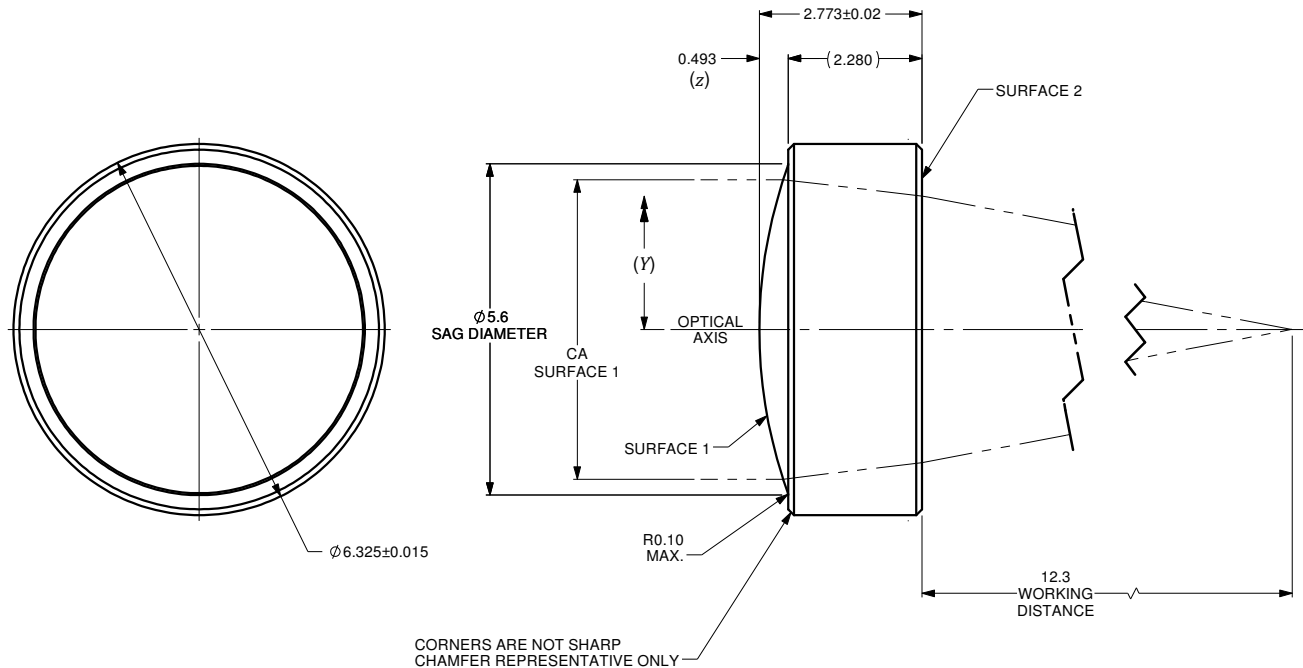

NUMERICAL APERTURE	0.18
EFFECTIVE FOCAL LENGTH	14.1mm

NOTES :

- MATERIAL: D-ZK3
- WAVEFRONT ABERRATION (RMS): <0.05λ @ 632.8nm
- AR COATING: 1000-1650 nm
REFLECTIVITY R_{max} <1.00%

ALL DIMENSIONS ARE IN MILLIMETERS		A	N/A	ORIGINAL ISSUE	C.M.	10-SEP-2019	
DRAWN BY: P. SUMMERS	DATE: 9/10/2019	REV.	ECR REF#	DESCRIPTION	ENG. BY	DATE	
CHECKED BY:	DATE:	UNLESS NOTED OTHERWISE, DIMENSIONS ARE IN MILLIMETERS, INCHES ARE IN SQUARE BRACKETS, AND TOLERANCES APPLY AS SHOWN BELOW.				PART BARCODE #: 4515	
M/S CHECKED BY:	DATE:	INCHES				219 WESTBROOK ROAD OTTAWA, ONTARIO CANADA K6A 1L0	
AP/VD BY:	DATE:	MILLIMETERS				www.ozoptics.com	
PROJECTION:		DESC: ASPHERIC LENS				f=13.9mm, OD=6.325mm. AR COATED FOR 1000-1650nm	
THIS PRINT IS THE EXCLUSIVE PROPERTY OF OZ OPTICS AND MUST BE RETURNED UPON REQUEST. UNAUTHORIZED USE, MANUFACTURE OR REPRODUCTION IN WHOLE OR IN PART IS PROHIBITED.		ANGULAR DIMENSIONS				PART NO: AS-F13.9-D6.3-1000/1650	
		SURFACE FINISH				REV: A	
		MILLED 125μ				SCALE: 12:1	
		PROFILED 63μ				DWG.# 4000-0233	
		SIZE: B				SHEET 1 OF 1	

A
4000-0233