



V-GROOVE CHIPS

Features:

- Up to 48 channel V-Groove arrays
- High accuracy V-Grooves using etched silicon or machined glass
- Compatible with 125/250 micron diameter singlemode, multimode and polarization maintaining fibers
- 0.5 micron channel spacing accuracy
- Designed to meet Telcordia requirements
- Silicon and glass versions

Applications:

- Pigtailling of integrated optical devices
- Connection to planar waveguide devices
- Attachment to an array of active devices
- Connection of MEMS devices and miniaturized fiber optic components
- Construction of DWDM and multi-channel devices

Product Description:

OZ Optics V-Groove chips assist in developing next generation photonic devices. The array components allow precise alignment of either ribbonized or individual fibers in a linear array. Utilizing OZ Optics V-Grooves with a Pyrex lid allows UV or heat curing of the fibers into the array and attachment to another device. The side wall design incorporated in the rear of the V-Groove chip enhances the overall assembly's strength and rigidity, and reduces breakages.

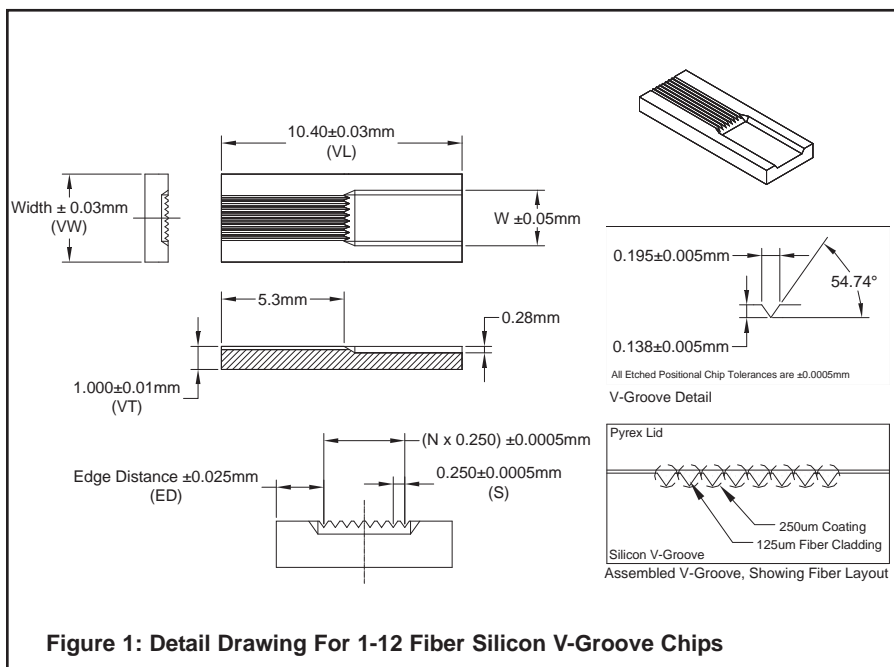
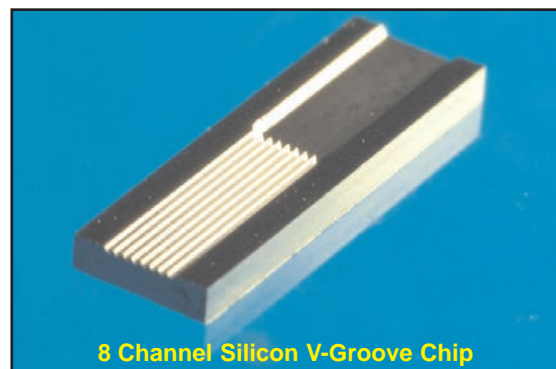
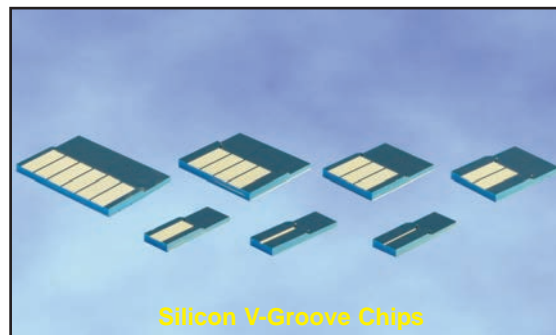

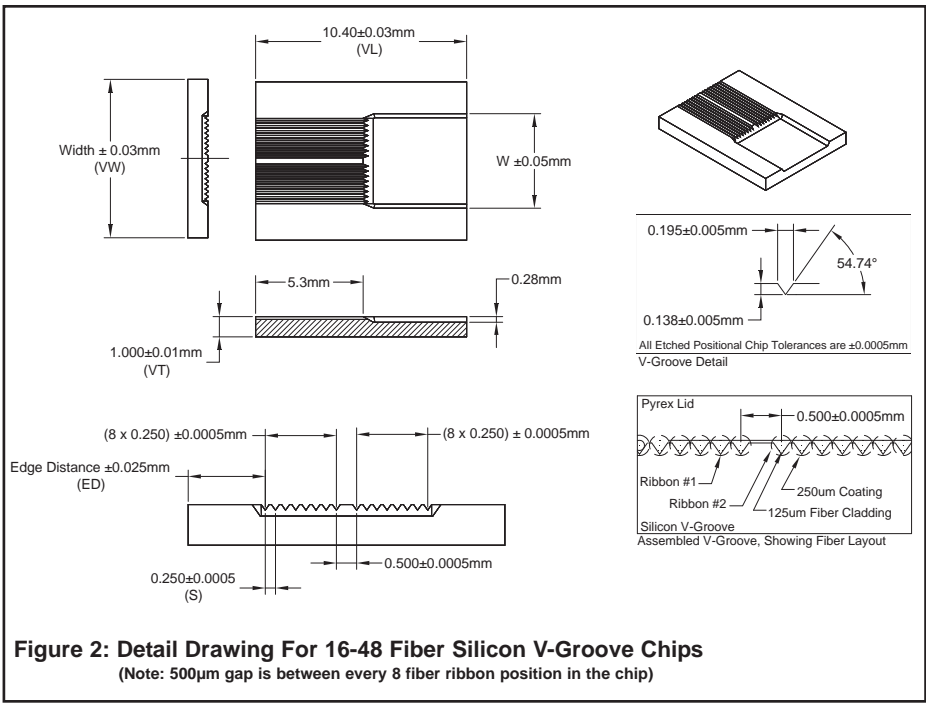

Figure 2: Detail Drawing For 16-48 Fiber Silicon V-Groove Chips
 (Note: 500µm gap is between every 8 fiber ribbon position in the chip)

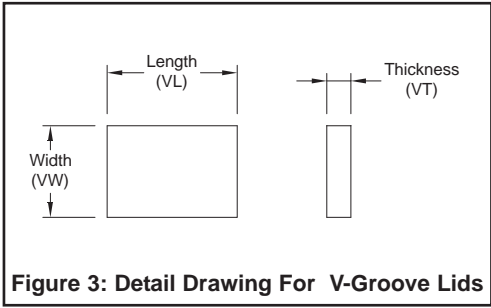

Figure 3: Detail Drawing For V-Groove Lids

Ordering Information For Standard Parts (V-Groove Chips):

Bar Code	Part Number	Description	Fiber Count (N)	Fiber Spacing (S)	V-Groove Length (VL)	V-Groove Width (VW)	Edge Distance (ED)	V-Groove Thickness (VT)
11767	VGC-1-250-10.4-3.8-1-SW	1 channel silicon V-Groove chip	1	250 µm	10.4 mm	3.8 mm	1.900 mm	1.0 mm
11768	VGC-2-250-10.4-3.8-1-SW	2 channel silicon V-Groove chip with 250 micron fiber spacing	2	250 µm	10.4 mm	3.8 mm	1.775 mm	1.0 mm
11773	VGC-4-250-10.4-3.8-1-SW	4 channel silicon V-Groove chip with 250 micron fiber spacing	4	250 µm	10.4 mm	3.8 mm	1.525 mm	1.0 mm
11774	VGC-8-250-10.4-3.8-1-SW	8 channel silicon V-Groove chip with 250 micron fiber spacing	8	250 µm	10.4 mm	3.8 mm	1.025 mm	1.0 mm
11769	VGC-12-250-10.4-5-1-SW	12 channel silicon V-Groove chip with 250 micron fiber spacing	12	250 µm	10.4 mm	5.0 mm	1.125 mm	1.0 mm
11775	VGC-16-250-10.4-7.8-1-SW	16 channel silicon V-Groove chip with 250 micron fiber spacing	16	250 µm	10.4 mm	7.8 mm	1.900 mm	1.0 mm
11770	VGC-24-250-10.4-8.3-1-SW	24 channel silicon V-Groove chip with 250 micron fiber spacing	24	250 µm	10.4 mm	8.3 mm	1.025 mm	1.0 mm
11771	VGC-32-250-10.4-11.8-1-SW	32 channel silicon V-Groove chip with 250 micron fiber spacing	32	250 µm	10.4 mm	11.8 mm	1.650 mm	1.0 mm
11772	VGC-48-250-10.4-14.8-1-SW	48 channel silicon V-Groove chip with 250 micron fiber spacing	48	250 µm	10.4 mm	14.8 mm	0.900 mm	1.0 mm

Note: 500µm gap is between every 8 fiber ribbon position for chips larger than 12 fiber. Other configurations may be available upon request.

Ordering Information For Standard Parts (V-Groove Lids):

Bar Code	Part Number	Description	Fiber Count (N)	Lid Length (VL)	Lid Width (VW)	Lid Thickness (VT)
9686	VGC-LID-5.3-3.8-1	1,2,4 or 8 channel Pyrex V-Groove lid	1,2,4,8 fiber lid	5.3 mm	3.8 mm	1.0 mm
9689	VGC-LID-5.3-5-1	12 channel Pyrex V-Groove lid	12 fiber lid	5.3 mm	5.0 mm	1.0 mm
9690	VGC-LID-5.3-7.8-1	16 channel Pyrex V-Groove lid	16 fiber lid	5.3 mm	7.8 mm	1.0 mm
12597	VGC-LID-5.3-8.3-1	24 channel Pyrex V-Groove lid	24 fiber lid	5.3 mm	8.3 mm	1.0 mm
12598	VGC-LID-5.3-11.8-1	32 channel Pyrex V-Groove lid	32 fiber lid	5.3 mm	11.8 mm	1.0 mm
12599	VGC-LID-5.3-14.8-1	48 channel Pyrex V-Groove lid	48 fiber lid	5.3 mm	14.8 mm	1.0 mm

Specifications:

V-Groove Chips:

Fiber Count	1,2,4,8,12,16,24,32,48
Thickness	1.00mm
Channel Spacing	250um standard, others available upon request
Channel Spacing Accuracy	±0.5 micron absolute
Fiber Diameter	Accommodates 125µm diameter fibers with up to 250µm diameter primary coatings. Coating diameters of up to 400µm can be used at 500µm spacing
Fiber Type	Individual fibers or ribbonized fibers

Pyrex Lids:

Fiber Count:	1,2,4,8,12,16,24,32,48
Thickness	1.00mm
Material	Pyrex

Ordering Examples For Standard Parts:

A customer needs to build an 8 fiber V-Groove assembly using an 8 fiber ribbon. The following parts will be required:

Bar Code	Part Number	Description
11774	VGC-8-250-10.4-3.8-1-SW	8 channel silicon V-Groove chip with 250 micron fiber spacing
9686	VGC-LID-5.3-3.8-1	1,2,4 or 8 channel Pyrex V-Groove lid

Ordering Information For Custom Parts:

OZ Optics welcomes the opportunity to provide custom designed products to meet your application needs. As with most manufacturers, customized products do take additional effort so please expect some differences in the pricing compared to our standard parts list. In particular, we will need additional time to prepare a comprehensive quotation, and lead times will be longer than normal. In most cases non-recurring engineering (NRE) charges, lot charges, and a 50 piece minimum order will be necessary. These points will be carefully explained in your quotation, so your decision will be as well informed as possible. We strongly recommend buying our standard products.

Questionnaire For Custom Parts:

1. How many fiber positions does your application require?
2. What spacing between fibers does your application require?
3. If you are going to use ribbon, is it standard 8 or 12 fiber count?
4. If you are using individual fibers, what is the coating diameter?
5. Do you need a lid for final assembly?

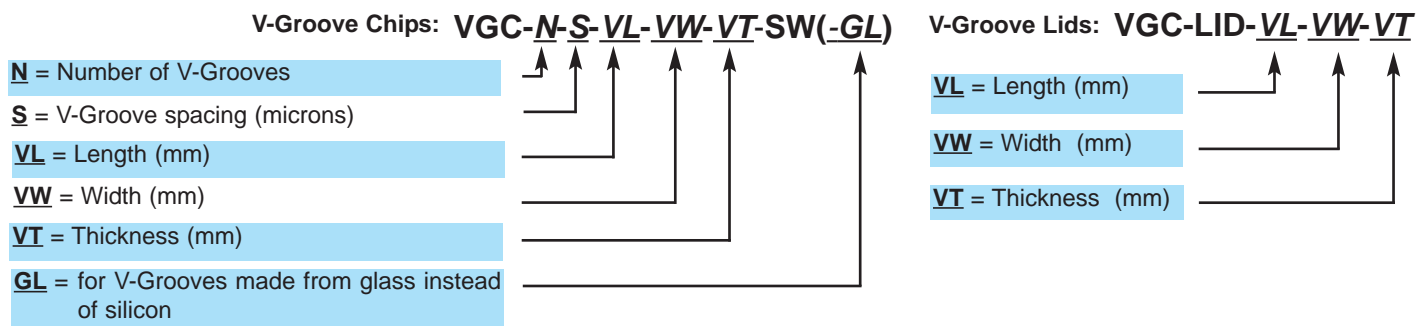

Ordering Examples For Custom Parts:

A customer needs to purchase a custom V-Groove chip and matching Pyrex lid. The required specifications are that the V-Groove chip have 10 V-Grooves with 325 micron spacing, be 7mm wide, 15mm long and 1mm thick, the V-Groove length is to be standard (5.3mm).

Part Number	Description
VGC-10-325-15-7-1-SW	10 Channel silicon V-Groove Chip with 325 μ m fiber spacing
VGC-LID-5.3-7	Custom Pyrex V-Groove Lid

Frequently Asked Questions (FAQs):

Q: What are the standard materials used?

A: Silicon or glass for the V-Groove, Pyrex for the lid.

Q: Is the fiber core above or below the surface of the V-Groove chip?

A: Nominally the center of the core is seated approximately 30 microns below the surface of the chip.

Q: What types of adhesives can be used to adhere the fibers into the V-Grooves?

A: UV cured or thermally cured epoxies have been successfully used to mount the fibers into the V-Grooves. The matching Pyrex lids are necessary when using UV cured adhesives.

Q: Are two V-Groove chips used to sandwich the fibers in place?

A: No, the OZ Optics V-Groove chips are designed to be used with a flat lid, which provides a stable 3 point contact for positioning the fiber.

Q: Can individual fibers be assembled into the V-Groove chips?

A: Yes, the design allow for either individual or ribbonized fibers to be used. This also allows for mixing of different fiber types in the assembled chip.

Q: Are the V-Groove channel spacing tolerances cumulative?

A: No, the absolute tolerance from any one V-Groove to the reference V-Groove on a chip is ± 0.5 micron.

Application Notes:

OZ V-Groove Chip Design:

OZ Optics has designed the V-Groove chip to be used with a flat lid. The flat lid design allows the fibers to be accurately aligned in the chip by creating a 3-point contact area. The fiber will naturally sit in the V-Groove contacting at two points tangent to the fiber. By placing a flat lid over the top of the protruding fiber, creating the third point of contact, the fiber is guaranteed to be held in position, taking full advantage of the high accuracy of the silicon V-Groove chip. If alternatively, a second V-Groove chip is used for the top, creating a 4-point contact area, the tolerances of both chips can work against each other. This can create a potential for the fiber to be forced into an inappropriate offset position with only 2 points of contact, as well as the top and bottom chips not properly seating together, and thus not be parallel.

Silicon V-groove Chips:

Silicon is normally used to manufacture the V-Groove chips offered by OZ Optics. The silicon wafers are etched using highly accurate methods originally developed for the semiconductor industry. This process is very cost effective and repeatable in large manufacturing runs. Etching tolerances of 0.5 micron are easily achieved using this manufacturing process providing consistent and accurate products time after time. More recently OZ Optics has been able to manufacture V-Grooves using glass for special applications.

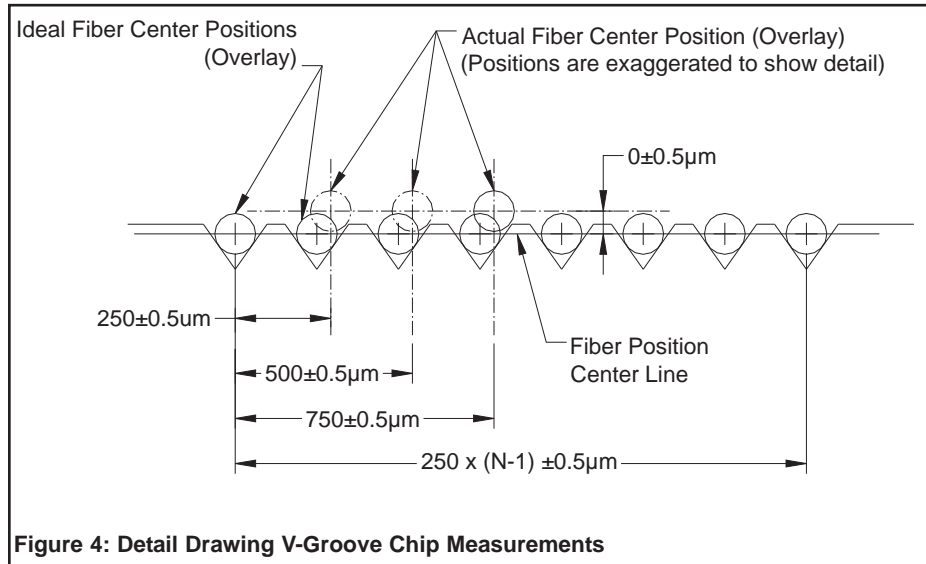

Figure 4: Detail Drawing V-Groove Chip Measurements

Measurement Method used by OZ Optics:

OZ Optics uses a highly accurate automated measurement system to verify the dimensions of the V-Groove chip pitch (V-Groove spacing). The system uses a back illumination method and machine vision to determine the exact angle and location of each V-Groove. An ideal fiber diameter is then overlaid by the system to determine where the center of the fiber would be positioned in the groove. Based on the location of these virtual fibers, the system creates a centerline between the first and last fiber and measures the actual placement of all other fiber centers relative to that centerline. This method of measurement gives the most realistic measurement results for the intended application. The detail drawing (Fig. 4) shows graphically the measurement method used and the allowable offset from the ideal positions.

Cleanliness During Assembly:

One important thing to consider when assembling the fibers into the V-Groove chip is the chip and fiber cleanliness. Any dust or debris in the V-Groove area or on the fiber can cause many performance or reliability problems during usage including positional offset of the fiber leading to high insertion losses, air bubbles in the epoxy leading to environmental stresses or latent stress failures and adhesion problems over temperature and humidity. Cleaning with isopropyl or higher grade alcohol along with drying by baking or blowing with clean dry filtered air is recommended prior to assembly.

Adhesive Selection:

When choosing an adhesive for assembly several things need to be considered including adhesive application, curing time and temperature, the adhesion properties for the materials being used, and the environmental extremes the device is designed to be used in. UV cure and Heat cure adhesives are both commonly used for the assembly of these devices. If assembling using the OZ Optics Pyrex lid, UV adhesives can be used to quickly and accurately adhere the lid and fibers in place. Heat cure adhesives typically take much longer to set than the UV cure adhesives but may offer different cured properties that can be advantageous to some applications. Please consult with your adhesive supplier for the best product for your application.

Handling Precautions:

It is strongly recommended to handle the V-Groove chips and lids using either soft tip tweezers or powder free latex gloves. Use of any metal instrument to move or pick-up the parts will cause chipping of the edges. By using powder free latex gloves the risk of getting oils from your skin and other contaminants which would cause adhesion problems onto the chip is greatly reduced.

Assembly Tips:

1. Clean the chips, lids, and fibers thoroughly prior to assembly.
2. Apply adhesive such that the air bubbles are eliminated or minimized.
3. Apply even and consistent pressure to the lid to ensure good 3-point contact of the fiber and to minimize stresses during the curing process.
4. Apply a protective coating of epoxy over the entire stripped portion of the fiber exiting the V-Groove region to eliminate environmental damage to the exposed fibers.
5. Cleave the fibers using a scribe prior to polishing to eliminate damage to the fibers below the chip surface.
6. Avoid any bends in the fiber exiting the V-Groove region and off of the back of the chip.