



OZ Optics

shop.ozoptics.com
www.ozoptics.com

219 Westbrook Road
Ottawa, ON, Canada, K0A 1L0

Toll-free: 1-800-361-5415
Telephone: 1-613-831-0981
Fax: 1-613-836-5089
sales@ozoptics.com

DIGITAL DIRECTIONAL INLINE OPTICAL POWER MONITOR/METER

Patent numbers: Canada 2,494,133, USA 7095931, 7295731, China 1672073, and Europe 03766088.3

Features:

- Low insertion loss
- Continuous fiber. No interruptions to optical path
- Display units are interchangeable
- Wide dynamic range
- High power handling
- Polarization maintaining (PM) fiber versions available
- Rugged and compact design
- Long battery life
- Automatic shut off
- RS-232 interface option available
- Analog output option available

Applications:

- Optical power control devices
- Channel balancing for WDM systems
- Dynamic optical amplifier gain monitoring
- Power monitoring
- Network monitoring
- Real time in-line test and measurement
- Network installation
- Fiber optic sensor

Product Description:

Using a new, patented process, OZ Optics, as part of its new series of inline optical power monitors and tap couplers, now offers a digital inline optical power monitor (for more details about OEM optical power monitors, see the "Directional Fiber Optic Power Monitors (Taps/Photodiodes)" data sheet http://www.ozoptics.com/ALLNEW_PDF/DTS0042.pdf). Based on a groundbreaking new fabrication process, these all-fiber taps and monitors provide a way to easily measure the average signal intensity through an optical fiber via tapped light channeled into a built-in photodiode, without interrupting the traffic. The photodiode produces a signal proportional to the optical power traveling through the fiber with high directivity.

The OPM-200 product integrates a novel inline optical tap with a low noise InGaAs detector in combination with a high dynamic range logarithmic amplifier. The built-in microcontroller processes and displays the power transmitted through the selected fiber channel on an LCD display.

The optical tap modules and display units are independently calibrated, so any display unit can be plugged into any tap module and the measured power will be automatically calibrated. A low voltage circuitry design ensures a long lifetime for the built-in battery.

The detector module can be calibrated for either a single wavelength or for a broad wavelength range. Optional, RS-232 and analog outputs are also available.

The OPM-200 is ideal for network monitoring, out of specification alarms, and/or DWDM systems for real time monitoring and feedback. Our inline taps are highly directional and ideal for monitoring traffic traveling in one direction only. It may also be used for measuring return losses instead of transmitted power. In the same product family, OZ Optics now provides OEM single channel optical power monitors and can offer multi-channel power monitors for DWDM system integration, as per demand.



Inline Optical Power Monitor/ Meter With Digital Display



Inline Optical Power Monitor/Meter With Manually Variable Attenuator

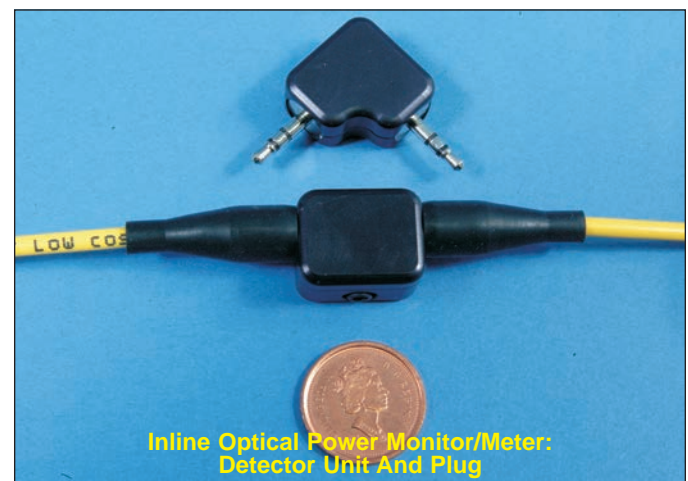

Inline Optical Power Monitor/Meter: Detector Unit And Plug

Ordering Information For Standard Parts

Bar Code	Part Number	Description
17054	OPM-200-1550-9/125-S-3U3U-3-1	Inline Optical Power Monitor including the detector module calibrated at 1550nm and the digital display. The fiber is 1m long on each side, 3mm OD jacketed 9/125 micron singlemode fiber with Ultra FC/PC connectors on both ends.
18138	OPM-200-1300-9/125-S-3U3U-3-1	Inline Optical Power Monitor including the detector module calibrated at 1300nm and the digital display. The fiber is 1m long on each side, 3mm OD jacketed 9/125 micron singlemode fiber with Ultra FC/PC connectors on both ends.
18405	OPM-200-1550-9/125-S-3U3U-3-1-DET	Inline Tap detector module calibrated at 1550nm. The fiber is 1m long on each side, 3mm OD jacketed 9/125 micron singlemode fiber with Ultra FC/PC connectors on both ends.
20068	OPM-200	Optical Power Monitor display unit. Battery powered only, right angled detector interface plug is included.
28748	AC-12VDC-Multi-Plug-Z	Power supply, 18 Watts, 12 V DC output, 1.5 A with multiplug for different countries.

Ordering Example For Standard Parts:

A North American customer needs to monitor a 1300nm signal and a 1550nm signal before reaching a WDM combiner. The customer should order one OPM kit for 1310 nm (including a detector module, a display module and a plug) and only the detector module for 1550 nm as follows:

Bar Code	Part Number	Description
18138	OPM-200-1300-9/125-S-3U3U-3-1	Inline Optical Power Monitor including the detector module calibrated at 1300nm and the digital display. The fiber is 1m long on each side, 3mm OD jacketed 9/125 micron singlemode fiber with Ultra FC/PC connectors on both ends.
18405	OPM-200-1550-9/125-S-3U3U-3-1-DET	Inline Tap detector module calibrated at 1550nm. The fiber is 1m long on each side, 3mm OD jacketed 9/125 micron singlemode fiber with Ultra FC/PC connectors on both ends.

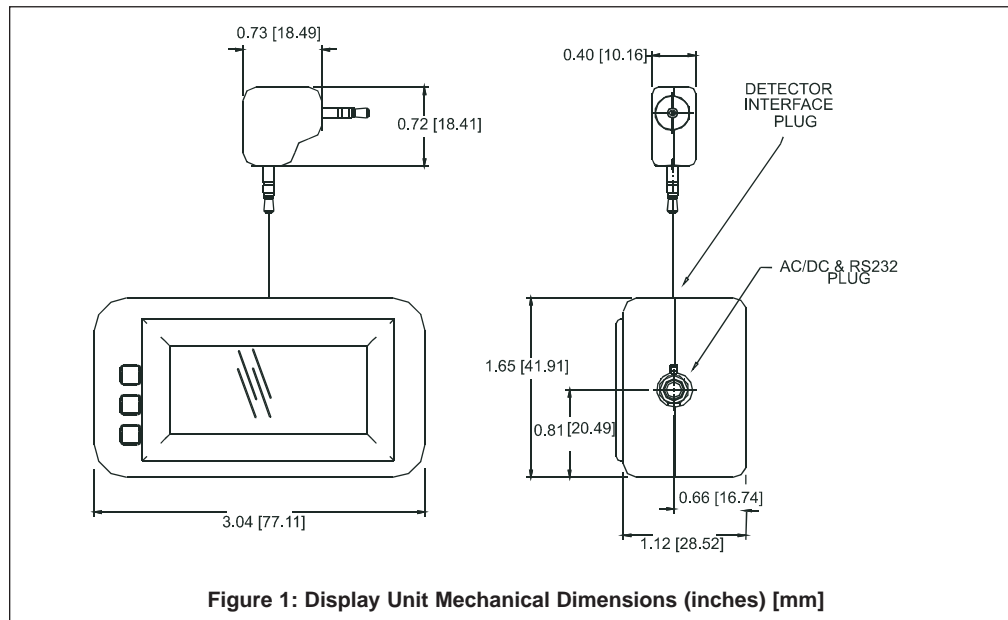

Standard Product Specifications¹

	Parameter	Specification
Part Number	OPM-200-1550-9/125-S-3U3U-3-1	
Detector Module	OPM-200-1550-9/125-S-3U3U-3-1-DET	
	Tap Ratio ²	1%
	Detector Type ³	InGaAs
	Fiber Type ³	9/125µm
	Fiber Jacket ³	3mm PVC
	Connector ³	FC/UPC
	Input Power Dynamic Range	-32 to +20dBm
	Wavelength Range	1250 to 1620nm with PIN InGaAs detector
	Calibrated Wavelength ⁴	1550nm
	Optical Return Loss	70dB (excluding connector)
	Directivity	35dB
	Polarization Dependent Response (PDR)	< 0.2dB
	Polarization Dependent Loss (PDL) along the transmission path	< 0.1dB
Display Module	OPM-200	
	Resolution	0.01dB
	Accuracy, at 23 °C	±5%
	Linearity	0.05dB (-20 to +10dBm)
	Measurement Units	dBm, dB
	Display	LCD
	Display Update Rate	1,2,4,8Hz (user selectable)
	Maximum Data Read-out Speed	1040 read-outs/s at 115 kbps, using RS-232
	Dimensions	77 x 42 x 30.2mm [3 x 1.65 x 1.19 inches]
	Weight	90g (0.20lb.) with battery
	Communications Interface	RS-232 serial port (optional)
	Baud Rate (Using RS-232)	9600, 19200, 38400, 56700, or 115200 bps
	Analog Output	0 to 0.8V analog output voltage across power dynamic range
	Battery	2 lithium coin batteries, type CR2477, 3V, 24mm in diameter
	Power supply	7.5 to 20 V (9 or 12 V typical @ 12 mA)
	Temperature Range: Operating Storage	0 to 70 °C [32 to 158 °F] -20 to 85 °C [-4 to 185 °F]
Humidity: Operating Storage	80% RH, non-condensing, at 0 to 50 °C [32 to 122 °F] 80% RH, non-condensing, at -20 to 60 °C [-4 to 140 °F]	

¹ Reference condition: 23 °C ambient temperature after 15 minute warm-up time.

² Other tap ratios as low as 0.1% (for high power monitoring applications) and as high as 4% (for low power measurement applications) are available upon request. The input dynamic range will then shift accordingly.

³ Other detector types, fiber types, fiber jackets and connectors are also available upon request.

⁴ Spectral calibrations are also available.

Ordering Information For Custom Parts:

Although we strongly recommend the purchase of our standard products, OZ Optics also welcomes the opportunity to provide custom-designed products to meet your application requirements. There can be a difference in the pricing for a custom-designed device or part compared to our standard parts list. Please consider the following points when reviewing your quotation:

- Additional time is required to prepare a comprehensive quotation.
- Lead times are usually longer than normal.
- Non-recurring engineering (NRE) charges and lot charges may apply.
- A five part minimum order is necessary.

These points will be carefully explained in your quotation, so you can make a well-informed decision.

Questionnaire for Custom Parts:

1. What is your operating wavelength range?
2. Do you need a single calibration wavelength or calibration across the entire wavelength range?
3. Do you need standard singlemode fiber or polarization maintaining fiber?
4. What is the expected optical power through the fiber, or what tap ratio do you need?
5. Do you need the ends of the fiber connectorized? What type of connector do you need?
6. How long should each end of the fiber be?
7. Do you need the fiber cabled? What cable size do you need?
8. Do you already have a display? Do you need a display with analog output, RS-232, or with both analog and RS-232?

Description

Kit: Detector Module With Display unit:

Part Number
OPM-200-W-a/b-F-XY-J-L(-C)

W: Calibrated Wavelength in nm: 980, 1310, 1480, 1550 or 1620 for single wavelength calibration and 1290/1620 for broad spectral calibration

a/b: Fiber core/cladding sizes, in μm :
9/125 for 1300/1550nm SM fiber.
6/125 for 980/1064nm SM fiber
8/125 for 1550nm PM Fiber

E: Fiber type S: Singlemode
P: Polarization maintaining fiber

X.Y Connector code:
3S = Super NTT-FC/PC
3U = Ultra NTT-FC/PC
3A = Angled NTT- FC/PC
SC = SC
SCA = Angled SC
8 = AT&T-ST
LC=LC
MU=MU

C: Communication interface:
Leave empty for no interface
A = Analog voltage interface
RS232 = RS-232 communication interface
A/RS232 = For both Analog and RS-232

L: Fiber Length in meters for each side

J: Jacket size: 1= 1mm OD loose tube Jacket
3= 3mm OD PVC cable

Description

Detector Module:

Part Number

OPM-200-W-a/b-F-XY-J-L-DET

W: Calibrated Wavelength in nm: 980, 1310, 1480, 1550 or 1620 for single wavelength calibration and 1290/1620 for broad spectral calibration

a/b: Fiber core/cladding sizes, in μm :
 9/125 for 1300/1550 nm SM fiber.
 6/125 for 980/1064 nm SM fiber
 8/125 for 1550 nm PM Fiber

F: Fiber type S: Singlemode
 P: Polarization maintaining fiber

L: Fiber Length in meters for each side

J: Jacket size: 1= 1mm OD loose tube jacket
 3= 3mm OD PVC cable

X,Y: Connector code:
 3S = Super NTT-FC/PC
 3U = Ultra NTT-FC/PC
 3A = Angled NTT- FC/PC
 SC = SC
 SCA = Angled SC
 8 = AT&T-ST
 LC=LC
 MU=MU

Description

Display unit:

Part Number

OPM-200(-C)

C: Communication interface:
 Leave empty for no interface (standard)
 A = Analog voltage interface
 RS232 = RS-232 communication interface
 A/RS232 = For both analog and RS-232

Ordering Example For Custom Parts:

A customer wants to see the strength of a signal in a PM fiber, spanning a 5-meter range between a source and a sensor. This could be done with the following parts:

Bar Code	Part Number	Description
20068	OPM-200	Optical Power Monitor display unit. Right angle detector interface plug is included. Battery powered. AC/DC adaptor not included.
N/A	OPM-200-1550-9/125-P-LCLC-3-5-DET	Inline Tap detector module calibrated for 1550 nm. The fiber is 5 m long on each side, with 3 mm OD jacketed 9/125 micron polarization maintaining fiber and LC connectors on both ends.

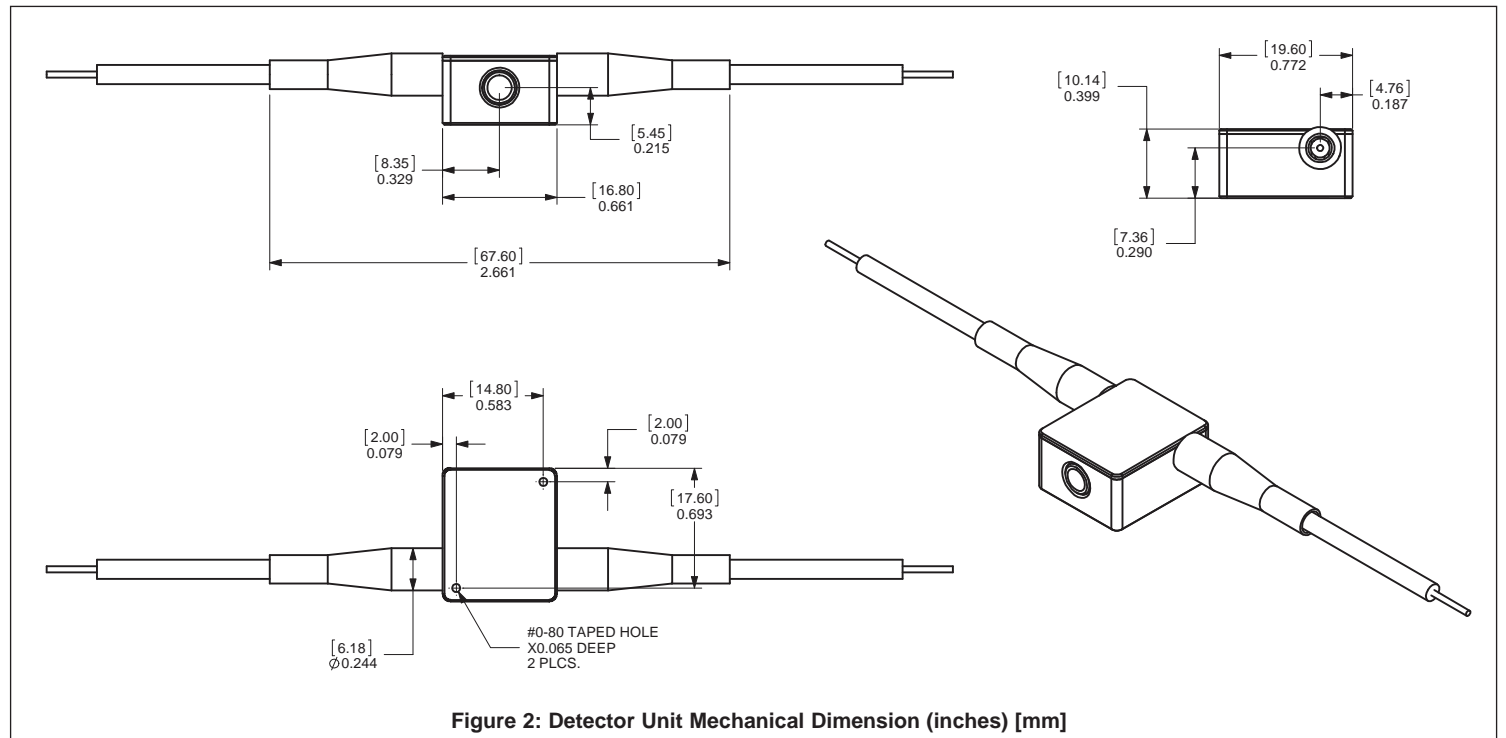

Frequently Asked Questions (FAQs)

Q: Can I use the OPM display unit with any inline detector module?

A: Yes, the OPM unit can read the average power transmitted through any inline detector regardless the wavelength and the fiber type. Each inline detector has a built in memory where calibration coefficients are saved.

Q: Can I operate the OPM-200 through Analog output mode or RS232 without supplying external Power?

A: No, in order to preserve the battery life time, when an analog cable or RS232 cable is plugged onto the display unit it will automatically disable battery power circuitry and you will need to supply at least 7.5 V DC (max. 20 V) in order to turn on the unit.

Q: Can I disable the auto shut-off feature?

A: No, this is a built in feature that allows saving battery lifetime, when no inline tap is connected, the display will shut off after about 5 minutes.

Q: How often should I check my meter's calibration?

A: Both display unit and inline tap come with one-year calibration warranty. It is recommended to send them back for calibration after each year.